



EATON Vickers Fixed Displacement Vane Pump

V and VQ series of single and double vane pump

www.hydpump.com

Intra-vane Mechanism

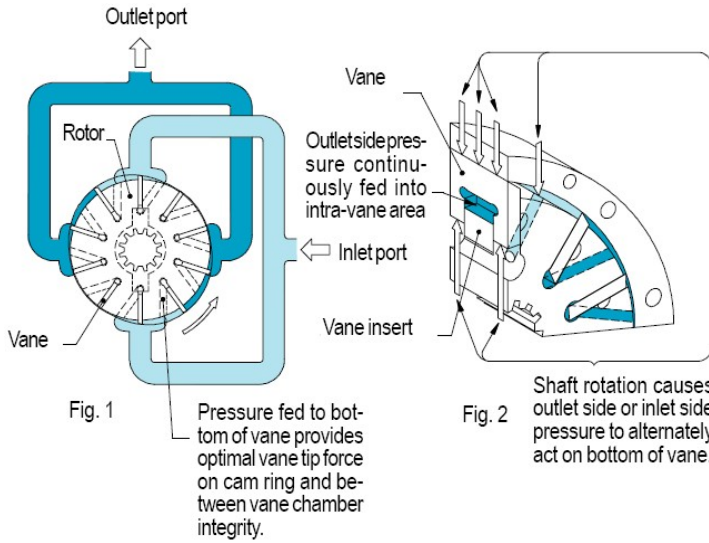

Features

- Eaton Vickers V and VQ series are fixed displacement and balanced type vane pumps. Available in both 12 vanes design for industrial application with quiet operating and 10 vanes design for mobile application with higher pressure and wider range of speed. They are widely used in hydraulic systems for machine-tools, presses, die casting machine, engineering, plastic injection molding and other machineries.
- Its interchangeable with original Vickers pump of the same model.
- The inlet or outlet ports can be rotated through increments of 90° in relation to each other, providing application flexibility and easy installation.
- With the cartridge independent of the shaft, allowing for easy change of flow capacity and field servicing without removing the pump from its mounting.
- For the cartridge kit of VQ Series, the flexible plates are inserted between the support plates and the rotor. The flexible plates are assembled with the bronze facing towards the rotor to improve cold start capability and compensate thermal expansion in the rotor. This makes VQ Series particularly suited for mobile application.

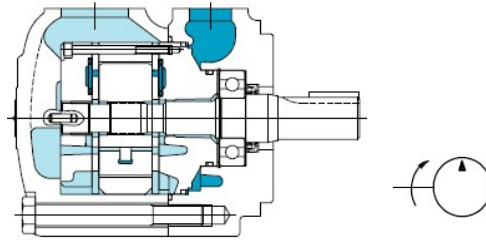

Single vane pump ordering code:

25	VQ	21	A	- 1	A	22	L	V
Model: 20,25, 35, 45	Series: V=industrial VQ=mobile	Displacement code	Port connections: A=SAE 4-bolt flange	Shaft type: 1=straight keyed 86=heavy duty keyed 11, 151=splined	Outlet port position: A=opposite inlet port B= -90° CCW from inlet C=inline with inlet D= -90° CW from inlet	Design number	Rotation: Viewed from shaft end R=clockwise (blank) L=anti-clockwise	Seal: Blank=buna V=viton

Port Positions for 20V/VQ:

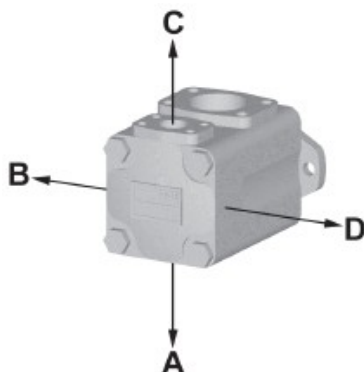

Port Positions for 25V/VQ, 35 V/VQ, 45 V/VQ:

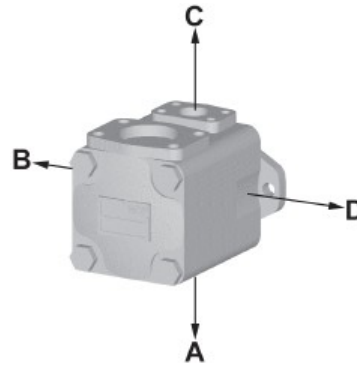

For more information and technical data, please contact us.